

PRODUCT INFORMATION PACKET



Model No: 326TSHFS19005BN

Catalog No: 811564.00

50HP..3550RPM.326.TEFC./V.3PH.60HZ.CONT.NOT.40C.1.15SF.RIGID.IEEE-841.326TSHFS19005AN
IEEE 841



Regal and Leeson are trademarks of Regal Beloit Corporation or one of its affiliated companies.

©2018 Regal Beloit Corporation, All Rights Reserved. MC017097E





Nameplate Specifications

Output HP	50 Hp	Output KW	37.0 kW
Frequency	60 Hz	Voltage	460 V
Current	56.5 A	Speed	3552 rpm
Service Factor	1.15	Phase	3
Efficiency	93 %	Duty	Continuous
Insulation Class	F	Design Code	B
KVA Code	G	Frame	326TS
Enclosure	Totally Enclosed Fan Cooled	Overload Protector	No
Ambient Temperature	40 °C	Drive End Bearing Size	6312
Opp Drive End Bearing Size	6311	UL	Recognized
CSA	Y	CE	Y
IP Code	56		

Technical Specifications

Electrical Type	Squirrel Cage Inverter Rated	Starting Method	Line Or Inverter
Poles	2	Rotation	Reversible
Mounting	Rigid base	Motor Orientation	HORIZONTAL
Drive End Bearing	BALL	Opp Drive End Bearing	BALL
Frame Material	Cast Iron	Shaft Type	TS
Overall Length	28.87 in	Frame Length	13.00 in
Shaft Diameter	1.875 in	Shaft Extension	3.75 in
Assembly/Box Mounting	F1/F2 CAPABLE		
Outline Drawing	B-SS301080LE-1300	Connection Diagram	A-EE7300U-LE

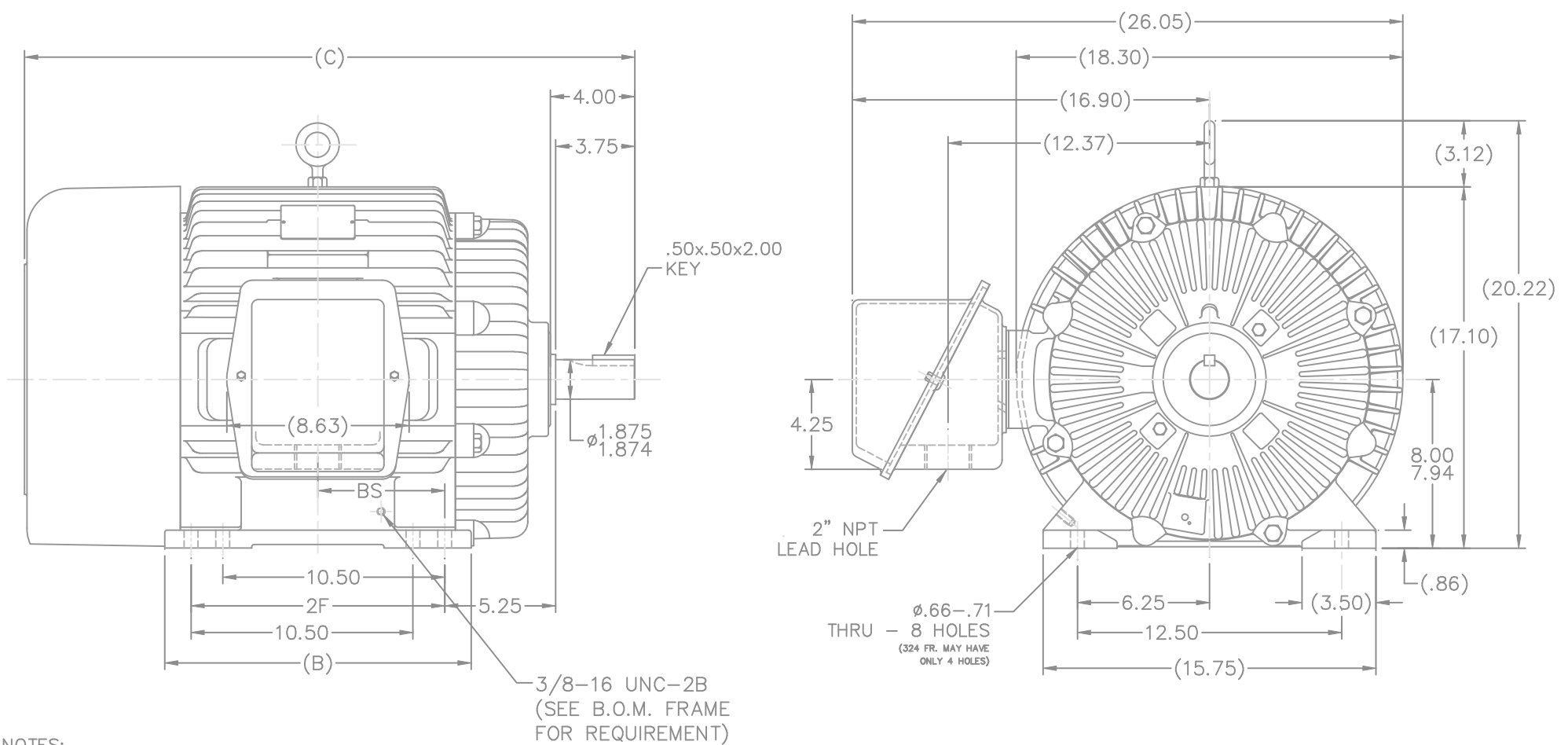

- NOTES:
 1. BOX CAN BE ROTATED IN 90° STEPS.
 2. BOX CAN BE MOUNTED ON OPPOSITE SIDE BY REMOVING BRACKETS AND TURNING FRAME 180°.
 3. NAMEPLATE TO BE READ FROM CONDUIT BOX SIDE OF MOTOR.

DASH	FR.	C	B	BS	2F
1150	324TS	27.37	13.00	5.25	10.50
1300	324/6TS	28.87	14.50	6.00	12.00

		TOLERANCES UNLESS SPECIFIED		LEESON	ELECTRIC MOTORS GEARMOTORS AND DRIVES	DRAWN RWR 10-29-2008	
NO.	REVISION	DEC.	INCHES			CHK	ML 10-29-2008
		.X	±.1			APPD	DR 10-29-2008
		.XX	±.03		TITLE	SCALE	1=5
		.XXX	±.005		OUTLINE	REF	B-SS301080
		.XXX	±.0005		320TS FRAME -TEFC	FMF	MU87713
					MAT'L	PREV	
		CHK	ANG	±7'30"	FINISH	SIZE	DRAWING NO. PAGE 1 OF 1 REV.
THIS DRAWING IN DESIGN AND DETAIL IS OUR PROPERTY AND MUST NOT BE USED EXCEPT IN CONNECTION WITH OUR WORK ALL RIGHTS OF DESIGN AND INVENTION ARE RESERVED THIS IS AN ELECTRONICALLY GENERATED DOCUMENT - DO NOT SCALE THIS PRINT				RFP	10-29-2008	CAD FILE	SS301080LE
		DIST	LB			B	SS301080LE

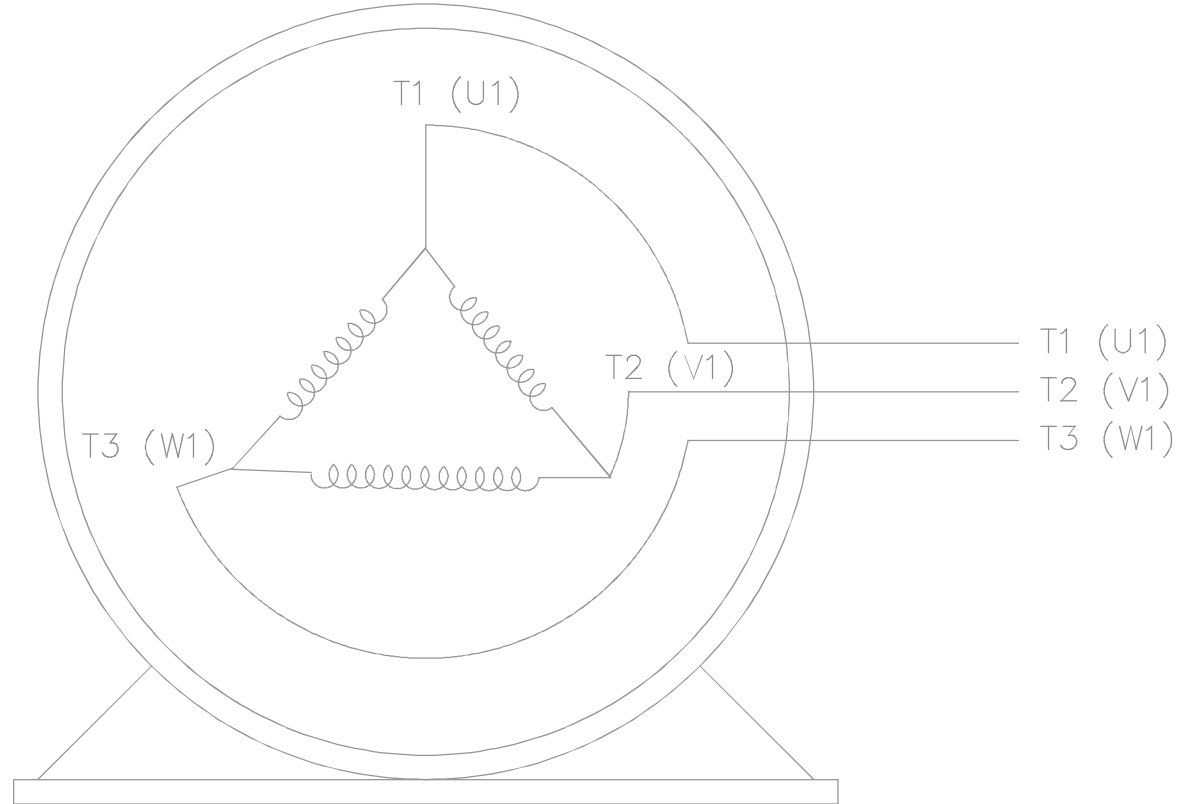

VIEW OF TERMINAL END

IF MOTOR HAS MULTIPLE
T'S PER LEAD CONNECT
TOGETHER LIKE T'S

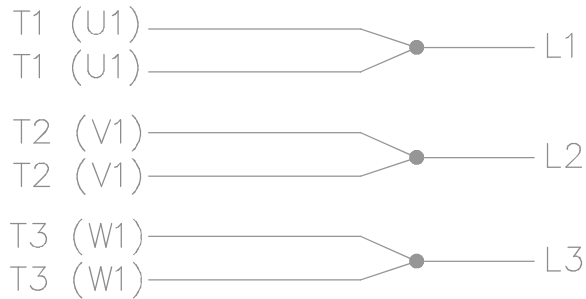

			TOLERANCES UNLESS SPECIFIED		 ELECTRIC MOTORS GEARMOTORS AND DRIVES	DRAWN KL 03-24-2003	
			DEC.	INCHES		CHK GFH 03-24-2003	APPD JES 03-24-2003
			.X	± -	TITLE CONNECTION DIAGRAM 3Ø SINGLE VOLTAGE MAT'L. FINISH	SCALE 1=1	REF
			.XX	± -		REF	FMF
			.XXX	± -		PREV	
			.XXXX	± -			
1	NEW DRAWING MU45909	KL 03-24-2003					
NO.	REVISION	BY & DATE	CHK	ANG	FINISH	SIZE	DRAWING NO. PAGE OF REV.
						A	EE7300U-LE 1

THIS DRAWING IN DESIGN AND DETAIL IS OUR PROPERTY AND MUST NOT BE USED EXCEPT
IN CONNECTION WITH OUR WORK ALL RIGHTS OF DESIGN AND INVENTION ARE RESERVED
THIS IS AN ELECTRONICALLY GENERATED DOCUMENT - DO NOT SCALE THIS PRINT

RFP CAD FILE EE7300U-LE
DIST WA



Motor Load Data								
Load	0%	25%	50%	75%	100%	115%	125%	LR
Current (Amps)	15.0	20.5	31.0	43.0	56.5	65.0	70.5	362
Torque (ft-lb)	0.00	18.0	37.0	55.0	74.0	85.0	93.0	118
RPM	3600	3590	3577	3585	3552	3543	3535	0
Efficiency (%)		88.5	92.4	93.6	93.0	93.0	92.4	
P.F. (%)	8.0	64.0	82.0	87.5	89.0	89.5	89.5	29.5

Motor Speed Data						Information Block																				
	LR	Pull-Up	BD	Rated	Idle	HP	Sync. RPM	Frame	Enclosure	Construction	Voltage	Frequency	Design	LR Code letter	Service Factor	Temp Rise @ FL	Duty	Ambient	Elevation	Rotor/Shaft wk ²	Ref Wdg	Sound Pressure @ 1M	VFD Rating	Outline Dwg	Conn. Diag	Additional Specifications:
Speed (RPM)	0	1800	3400	3552	3600	50.0	3600	326	TEFC	TFN	460	60	A	G	1.15	65	CONT	40	1,000	5.8	NONE	78	CONSTANT 2:1	B-SS301080LE-1300	A-EE7300U-1E	
Current (Amps)	362	330	215	56.5	15.0																					
Torque (ft-lb)	118	100	190	74.0	0.00																					

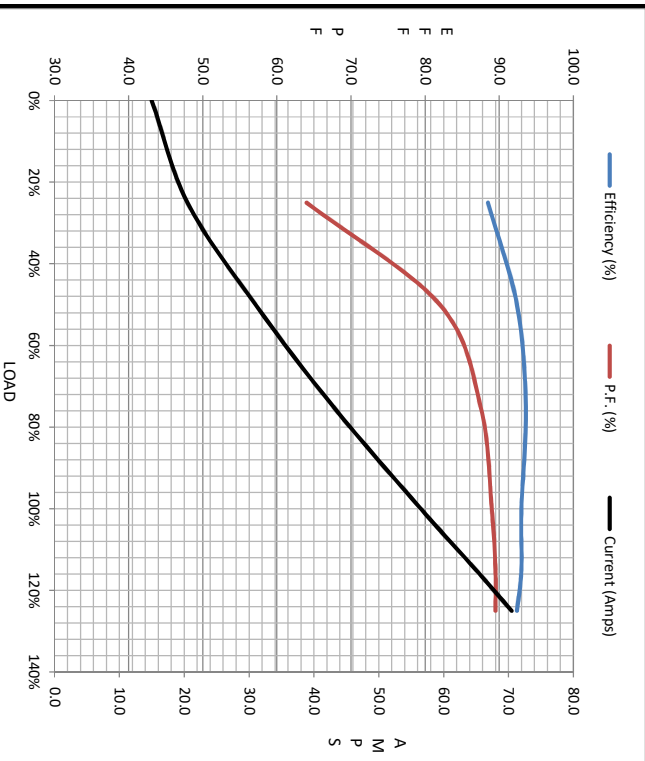

	R1	R2	X1	X2	Xm
EQUIV CKT (OHMS / PHASE)	0.0870	0.0650	0.3020	0.4540	17.8040
Additional Specifications:					
0					

